



**NOTICE OF DECISION ON A TYPE II LAND USE PERMIT**

**Decision:** Approved with Conditions

**Permit Type:** Temporary Dwelling for Care

**File No.** Z0293-22

**Proposal:** The applicant is proposing to renew a permit for a Temporary Dwelling for Care to continue to authorize the temporary placement of a manufactured dwelling, in addition to the primary dwelling, in the provision of care to a family member. The family member, who requires care due to age-related and medical conditions, would continue to reside in the primary dwelling. The care providers, Ashley Powers-Ross & Cody Ross, would continue to reside in the temporary dwelling. This temporary dwelling has been on the property since 1997 (first approved with land use file# Z1680-97 under different ownership).

**Decision Date:** August 29, 2022

**Deadline for Filing Appeal:** September 12, 2022, at 4:00

Unless appealed, this decision is effective on September 12, 2022 at 4:00 pm

**Issued By:** Roman Sierra, Planner I, RSierra@clackamas.us

**Assessor's Map & Tax Lot(s):** 23E35 00701

**Site Address:** 22355 S Eaden Rd

**Applicant:** Cody Ross

**Owner of Property:** Loren & M. Darcy Powers

**Zoning:** Exclusive Farm Use (EFU)

**Community Planning Organization (CPO) for Area:**  
Redland – Fischers – Mill -Viola

Community Planning Organizations (CPOs) are part of the county's community involvement program. They are advisory to the Board of County Commissioners, Planning Commission and Planning and Zoning Division on land use matters affecting their communities. CPOs are notified of proposed land use actions and decisions on land within their boundaries and may review these applications, provide recommendations or file appeals. If this CPO currently is inactive and you are

interested in becoming involved in land use planning in your area, please contact the Community Involvement Office at 503-655-8552.

**OPPORTUNITY TO REVIEW THE RECORD:** The submitted application is available for review online at <https://acela.clackamas.us/citizenaccess/>. Select the Planning tab and enter the file number to search. Select Record Info and then select Attachments from the dropdown list, where you will find the submitted application. The complete application file is available for inspection at no cost by contacting the Planner listed on the first page of this decision. Copies of all documents may be purchased at the rate of \$2.00 per page for 8 1/2" x 11" or 11" x 14" documents, \$2.50 per page for 11" x 17" documents, \$3.50 per page for 18" x 24" documents and \$0.75 per sq ft with a \$5.00 minimum for large format documents.

**APPEAL RIGHTS:** Any party disagreeing with this decision, or the conditions of approval, may appeal this decision to the Clackamas County Land Use Hearings Officer. An appeal must include a completed County Appeal Form and a \$250.00 filing fee and must be **received** by the Planning and Zoning Division by the appeal deadline identified on the first page of this decision.

Appeals may be submitted in person during office hours (8:00 am to 4:00 pm Monday through Thursday, closed Friday and holidays). Appeals may also be submitted by email or US mail.

The County Appeal Form is available at [www.clackamas.us/planning/supplemental.html](http://www.clackamas.us/planning/supplemental.html). Any party or parties appealing this decision may withdraw their appeal at any time prior to the hearing or final decision by the Hearings Officer. A party wishing to maintain individual appeal rights may file an individual appeal and pay the \$250.00 fee, even if an appeal by another party or parties has been filed.

**Please check <https://www.clackamas.us/planning> for our current hours of in-office operation. Appeals may be submitted in person during office hours. Appeals may also be submitted by email or US mail.**

The County Appeal Form is available at [www.clackamas.us/planning/supplemental.html](http://www.clackamas.us/planning/supplemental.html). Any party or parties appealing this decision may withdraw their appeal at any time prior to the hearing or final decision by the Hearings Officer. A party wishing to maintain individual appeal rights may file an individual appeal and pay the \$250.00 fee, even if an appeal by another party or parties has been filed.

A person who is mailed written notice of this decision cannot appeal this decision directly to the Land Use Board of Appeals under ORS 197.830.

**APPLICABLE APPROVAL CRITERIA:** This application is subject to Clackamas County Zoning and Development Ordinance (ZDO) Section(s) 202, 401, 1204, 1307.

**PUBLIC AND AGENCY COMMENTS:**

Notice was sent to applicable agencies and owners of property within 750 feet. Comments were received **from:**

**NOTICE TO MORTGAGEE, LIENHOLDER, VENDOR OR SELLER: ORS CHAPTER 215 REQUIRES THAT IF YOU RECEIVE THIS NOTICE, IT MUST PROMPTLY BE FORWARDED TO THE PURCHASER.**

*Clackamas County is committed to providing meaningful access and will make reasonable accommodations, modifications, or provide translation, interpretation or other services upon request. Please contact us at 503-742-4545 or email [DRenhard@clackamas.us](mailto:DRenhard@clackamas.us).*

503-742-4545: ¿Traducción e interpretación? |Требуется ли вам устный или письменный перевод?翻译或口译? |  
Cán Biên dịch hoặc Phiên dịch? | 번역 또는 통역?

# Location Map

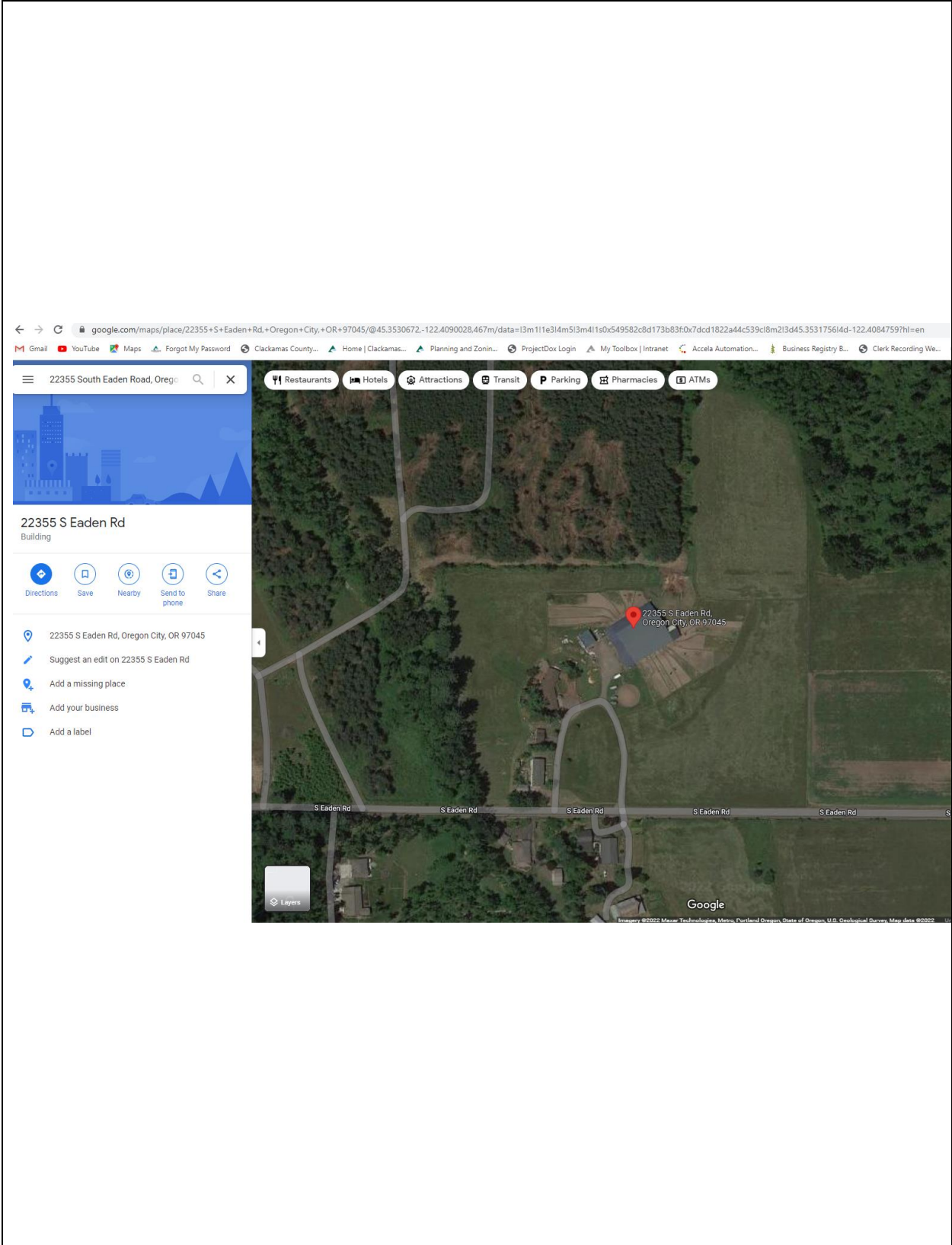

## Site Plan

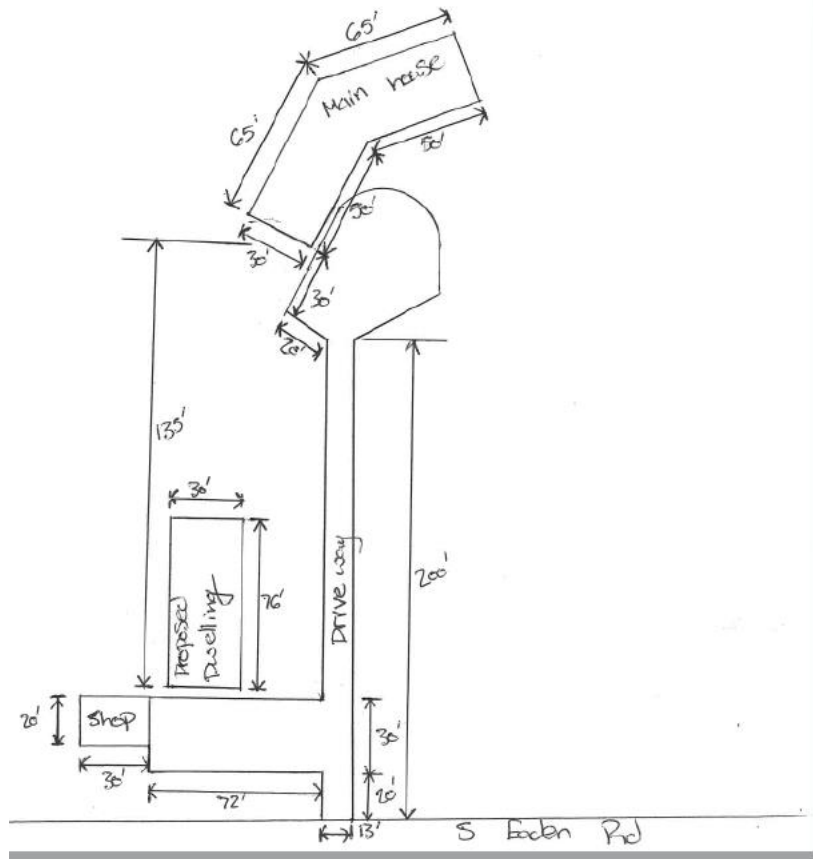

## CONDITIONS OF APPROVAL

The conditions listed are necessary to ensure that approval criteria for this land use permit are satisfied. Where a condition relates to a specific approval criterion, the code citation for that criterion follows in parentheses.

1. Approval of this land use permit is based on the submitted written narrative and plan(s) filed with the County on 6/14/22 along with the previously approved renewal of a permit for a Temporary Dwelling for Care file #Z0179-20. It shall be the responsibility of the property owner(s) to comply with this document(s) and the limitation of any approval resulting from the decision described herein.
2. Approval Period & Renewal: Approval of this renewal Temporary Dwelling for Care application is valid for 2 years from the date of the final written decision. The permit may be renewed, subject to review as a Type II application pursuant to Section 1307, for a period not to exceed 2 years. The permit may be renewed an unlimited number of times.

3. **Within 30 days of the date of this decision, the applicant shall contact the County's Septic & Onsite Wastewater Program at 503-742-4740 or [SoilsConcern@clackamas.us](mailto:SoilsConcern@clackamas.us) to apply for an Authorization Notice.** Any septic system that serves a single-family dwelling and is connected to the temporary dwelling must be reviewed every five years, in accordance with state law to ensure that the system is functioning, safe and properly maintained. The last documented Authorization Notice application was in 2020 SE055920. Failure to obtain the Notice may result in revocation of this temporary permit.
4. The temporary dwelling shall continue to be occupied by Ashley Powers-Ross, the care provider. The permanent dwelling shall continue to be occupied by Mertis Shelly, the care recipient.
5. The temporary dwelling shall continue to comply with the minimum yard depth standards for primary buildings in the applicable zoning district.
6. Utilities / Services: All water, electricity, natural gas, and sanitary sewer service for the temporary dwelling shall be extended from the permanent dwelling services. No separate meters for the temporary dwelling shall be allowed. An exception may be granted if the utility provider substantiates that separate service is required or if more than one lawfully established service exists on the subject lot of record or tract.
7. Driveway access: The temporary dwelling shall continue to use the same driveway entrance as the permanent dwelling.
8. Setbacks: The temporary dwelling shall continue to comply with the primary structure setback standards of the underlying EFU zoning district.
9. Separation Distance: The temporary dwelling shall continue to be located within 100 feet of the permanent dwelling (measured from the closest portion of each structure).
10. Deed Statement: A written statement shall continue to be recorded in the County deed records that continues to recognize that the temporary dwelling approved pursuant to Subsection 1204.04 is temporary and that the temporary permit is not transferable when the property is conveyed to another party.

**Finding:** *A deed restriction has been recorded with Clackamas County Doc# 2021-014451. This criterion is met.*

11. Rental Income: The temporary dwelling shall not be a source of rental income.
12. Removal / Storage: If the temporary dwelling is a manufactured dwelling or residential trailer, it shall be removed from the subject lot, parcel, or tract within 90 days of when the permit expires or the need for care ceases, whichever first occurs. An exception to this provision may be granted if a temporary manufactured dwelling is converted to a permanent dwelling. Such a conversion shall only be allowed if the temporary dwelling complies with all applicable requirements for a permanent dwelling, and if the conversion will not result in the subject lot, parcel, or tract's violating the density standards of the underlying zoning district. If the temporary dwelling is a recreational vehicle, it shall be

removed from the subject lot, parcel, or tract or placed in a stored condition when the permit expires or the need for care ceases, whichever first occurs. It is a violation of ZDO 1204 to leave a temporary dwelling on the subject property after the need for care ceases.

## FINDINGS

---

The findings below identify the standards and criteria that are relevant to this decision, state the facts relied upon in rendering the decision, and explain the justification for the decision.

**A. PROJECT OVERVIEW:** The applicant is proposing to renew a permit for a Temporary Dwelling for Care to continue to authorize the temporary placement of a manufactured home dwelling, in addition to the primary dwelling, in the provision of care to Mertis Shelley. Mertis Shelley, who requires care, as determined by a licensed health care professional, would continue to reside in the permanent dwelling with her husband, daughter and son-in-law. The care providers, Ashley Powers-Ross & Cody Ross would continue to reside in the temporary dwelling. This temporary dwelling has been on the property since 1997 (under different landowners and care recipient first approved with land use file #Z1680-97).

**B. ZDO Section 1204 Section Title**

Section 1204 of the ZDO, Temporary Permits, sets forth the process, standards and requirements for reviewing an application to renew a permit for a Temporary Dwelling for Care. The proposed renewal of a Temporary Dwelling for Care is subject to the criteria and standards of Section 1204 that are outlined below:

1204.04 TEMPORARY DWELLING FOR CARE

- C. Section 1204.04(C) provides a set of conditions of approval which are reflected in the previous section of this decision, under Conditions of Approval.
- D. A temporary permit for a dwelling for care may be approved for a period not to exceed two years in the EFU, TBR, and AG/F Districts and for a period not to exceed three years in any other zoning district. The permit may be renewed, subject to review as a Type II application pursuant to Section 1307, for a period not to exceed two years in the EFU, TBR, and AG/F Districts and three years in any other zoning district. A temporary permit for a dwelling for care may be renewed an unlimited number of times.

***Finding:*** *The Temporary Dwelling for Care is located in the EFU Zoning District, and was previously approved for a period not to exceed 2 years. The*

*permit is being renewed subject to this review as a Type II application pursuant to Section 1307. **This criterion is met.***

E. In lieu of Subsections 1204.04(A) and (B), a renewal application shall be subject to the following standards and criteria:

1) The circumstances that provided the basis on which the previous permit was granted remain substantially similar.

***Finding:** Staff has evaluated the submitted renewal application materials, and finds that the circumstances that provided the basis on which a previous permit was granted (under File No.Z0179-20) continue to remain substantially similar. Applicable Conditions of Approval that are the same conditions from the previous approval are outlined above to ensure that those circumstances continue to remain substantially similar. **This criterion is met.***

2) A renewal application shall be accompanied by a signed statement from a licensed healthcare provider. The statement shall be dated within 90 days preceding the date the application is submitted and shall identify the care recipient and substantiate that the level of assistance required is substantially similar to, or greater than, the level required when the previous permit was granted.

***Finding:** The applicant has provided a signed statement from Karoline Woitke, PA-C, a licensed healthcare provider, dated 6/1/22. The statement identifies that Mertis I Shelley has medical conditions that continue to require the same, or greater, level of assistance that was required when the previous permit was granted. **This criterion is met.***

F. An application shall be evaluated as a renewal application rather than a new application if the permit is requested for the same lot, parcel, or tract and the same care recipient as the previous permit.

***Finding:** The application is being evaluated as a renewal of a permit for a Temporary Dwelling for care, rather than a new application, because the permit is requested for the same lot as the previous permit and the care recipient, Mertis Shelley, is the same care recipient as the previous permit. The temporary dwelling will continue to be occupied by Ashley Powers-Ross & Cody Ross, who is providing care to Mertis Shelley. The permanent dwelling will continue to be occupied by Mertis Shelly who is to receive care from Ashley & Cody Ross. **This criterion is met.***